

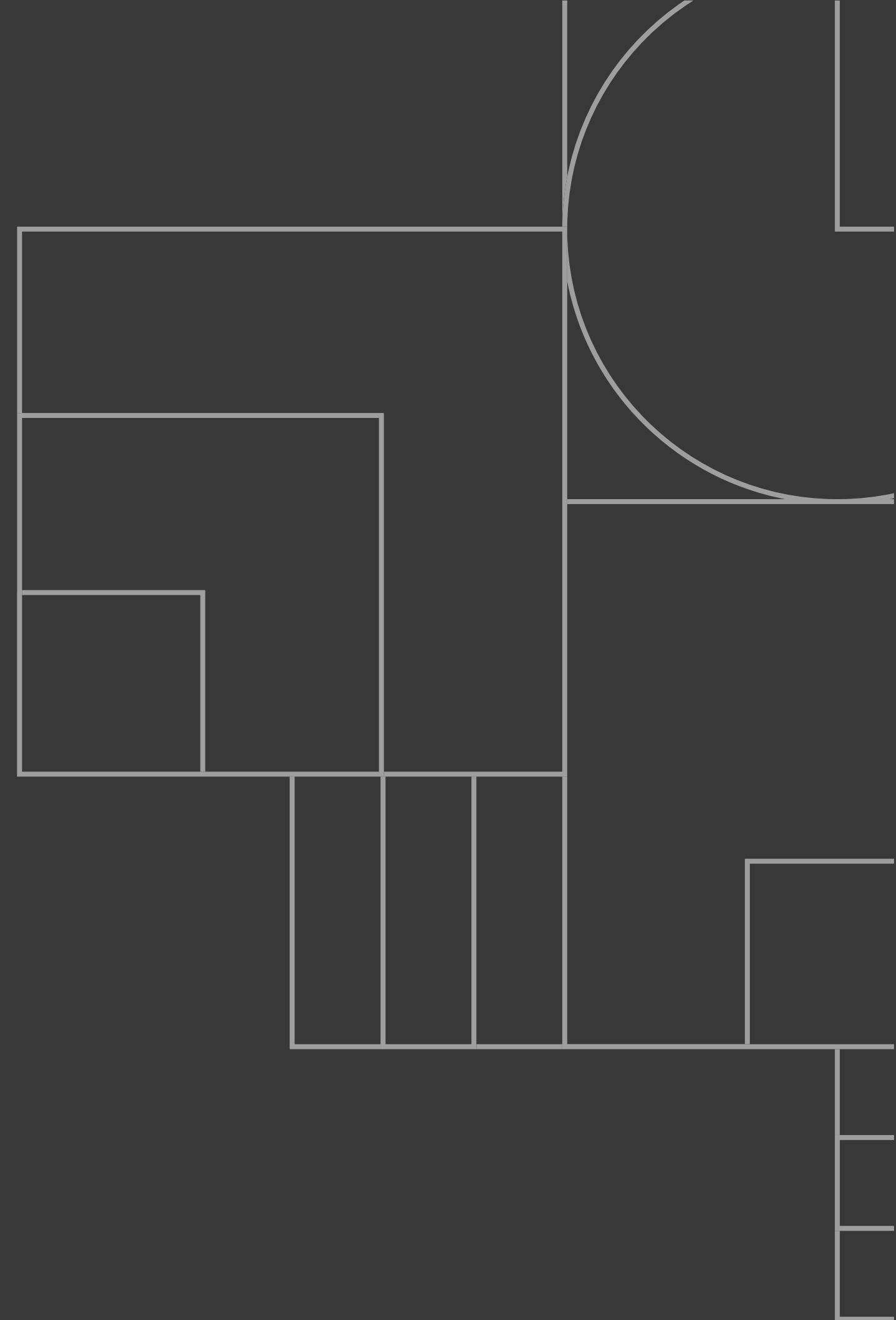

**Head turning, heart stopping, spirit lifting,
life loving, earth shaking, reputation making,
paradigm shifting presentations, brand
communications and digital experiences.**

Manchester's Specialist Manufacturing & Tech Creative Team

www.hnwagency.com



Message First, Results Follow

You're not just selling products or services - you're selling expertise and innovation. You're selling smart solutions to complex problems. You're selling trust.

But remember, **it's not the 'best' tech that wins - it's the best understood.**

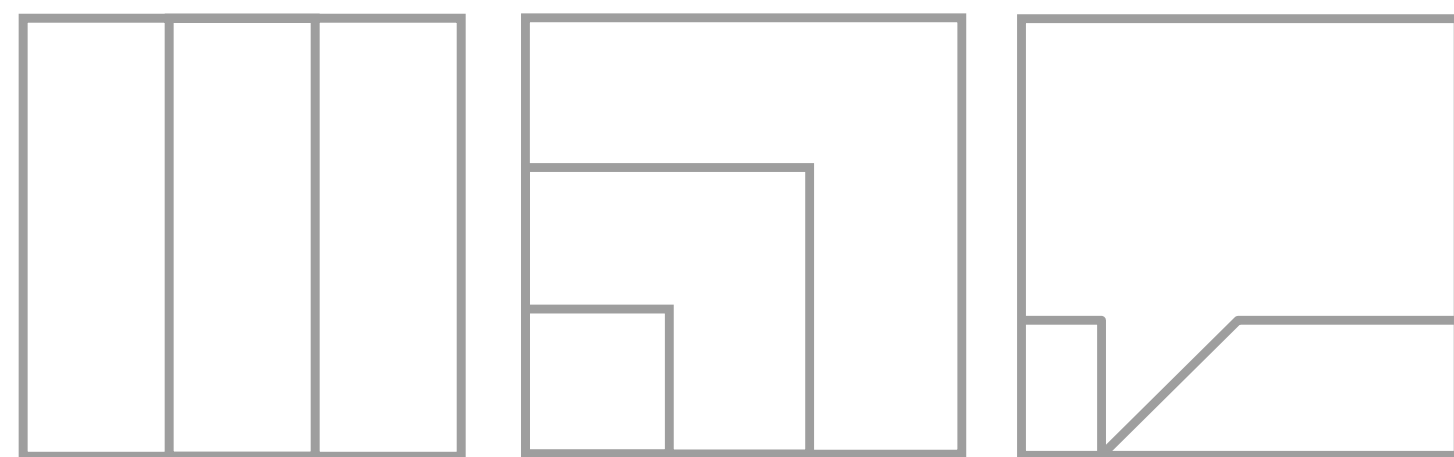

The Impact of Our Design and Message Work

- Shortened sales cycles as clients understand your value proposition more quickly
- Increased conversion rates on RFQs (one client saw an 18% increase in six months)
- More inbound enquiries specifically mentioning capabilities highlighted in your communications
- Greater engagement at trade shows with technical decision-makers
- Consistent messaging across all teams and touchpoints
- Distinctive presence in the “sea of sameness”

Be Understood

14+ years of specialist experience across the manufacturing and technology sectors, shaping brands and campaigns for leading manufacturing, engineering, and technology businesses, tells you that not only do we understand your challenges - we know exactly what it takes to share your value in the most valuable ways possible.

“These guys have transformed how we approach our marketing. They genuinely understand the real-world benefits of our work to create campaigns that not only look great but actually articulate our value proposition in ways our customers understand.”

Technical Director, Precision Components Ltd

Because successful marketing isn't just about slick visuals.

It's about translating often complex technical capabilities into crystal clear benefits. It's about articulating value in a way that resonates with both technical decision-makers and procurement teams. It's about ultra-relevant, resonant and readable messaging.

Ultimately, it's about inspiring confidence to drive commercial outcomes.

And it's about partnering with a proven creative team to achieve all that.



We Hear You. We Hear Marketing Managers

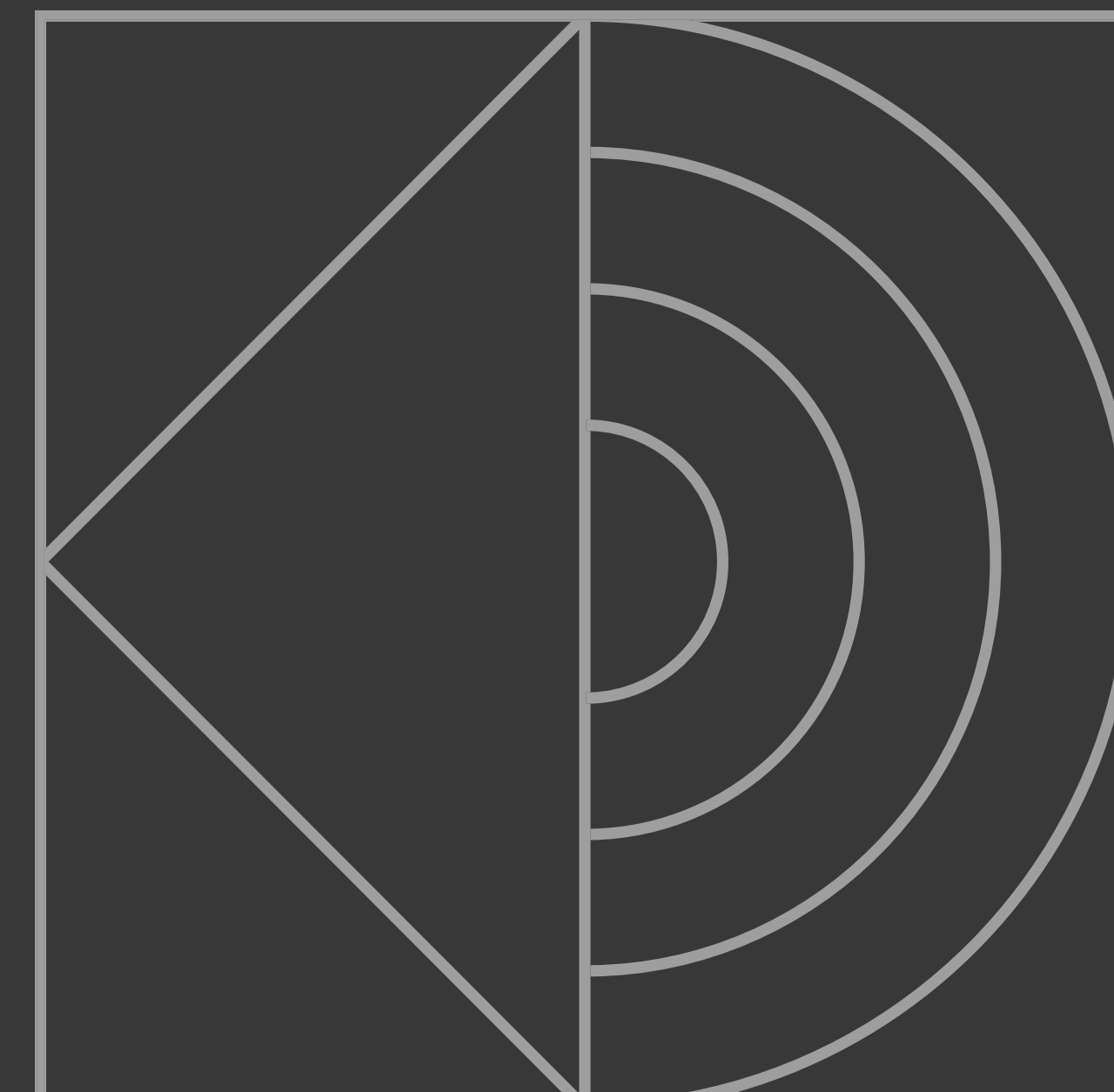

“I need marketing that bridges the gap between our engineers and our customers.”

Our work is designed to translate technical expertise into clear customer benefits so your innovation story reaches the right people in a language they understand.

“Who’s actually looking after my project day-to-day?”

We are - from concept to completion. No bait, no switch and no juniors. You’ll work directly with our senior creatives.

“I’m spending too much time trying to coordinate different suppliers and explaining our technology to freelancers.”

Our design and message service covers everything from brand development to video scripts, removing the need to manage multiple agencies so your value is clear and consistent across every touchpoint.

“

“The difference with this creative team is their ability to get their heads around complex manufacturing processes and translate their benefits into client-facing messaging. An integrated approach it’s eliminated the headache of constantly briefing different suppliers and ensured a consistent brand experience throughout our communications.”

Marketing Manager,
Advanced Engineering Solutions

We Hear Managing Directors and Owners

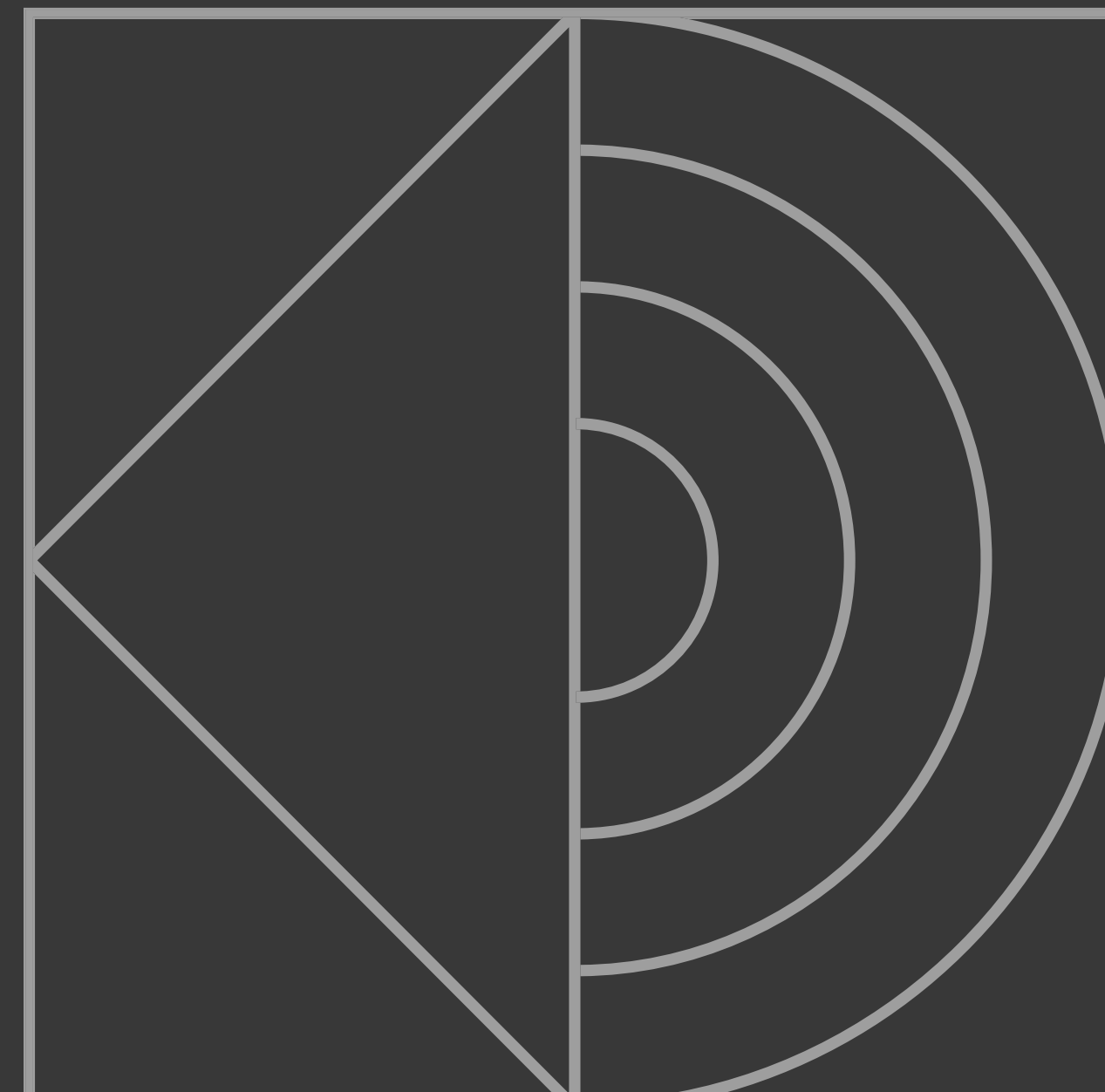

“I need marketing that generates quality leads and shortens our sales cycle.”

We create campaigns that help you connect with qualified prospects and articulate your value proposition clearly, so you can move from introduction to proposal more efficiently.

“I need a marketing partner who understands what makes our technology special.”

We get it - we understand the USPs of your innovation and how to communicate them to both technical and commercial audiences.

“The quality of our marketing needs to reflect the quality of our technology.”

We make sure your marketing looks and feels as sophisticated as your offering so you stand out in a competitive market.

“

“Our challenge was communicating complex technology in simple terms. In language that people understand - the language of savings, efficiencies and convenience. Their brand messaging achieves this perfectly, making our value proposition crystal clear. And the design work - amazing. It’s given everything we need to launch with 100% confidence. “

Angel Bozhilov,
CEO, Hydrogenica

We Hear Technical Directors

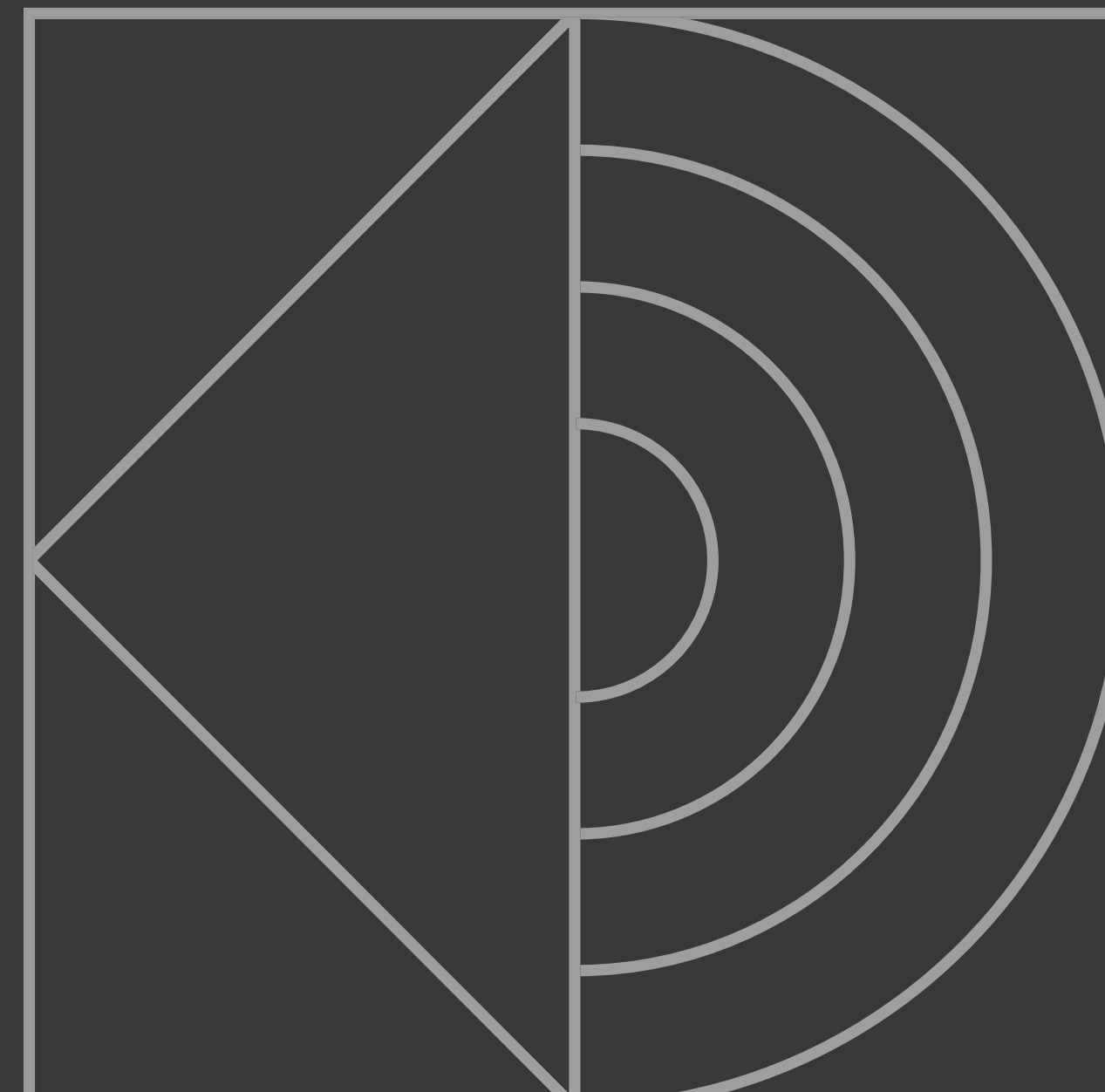

“I need marketing materials that actually understand our technology.”

We create compelling assets that showcase the genuine innovation in your products, answer technical questions before they're even asked, and make people want to find out more..

“I need someone who can make our complex capabilities understandable without dumbing them down.”

Accuracy with accessibility - it's a balance. We create campaigns that connect with both technical specialists and commercial decision-makers.

“I need people who won't misrepresent our technical capabilities.”

We know that in manufacturing and technology, credibility is everything. We're meticulous about accuracy yet still creating compelling narratives around your products and services.

“

“As technical leaders, we need marketing materials that respect the complexity of what we do. This team creates assets that genuinely excite potential clients without oversimplifying our capabilities.”

CTO,
Industrial Automation Systems

We Hear Fractional Marketing Directors

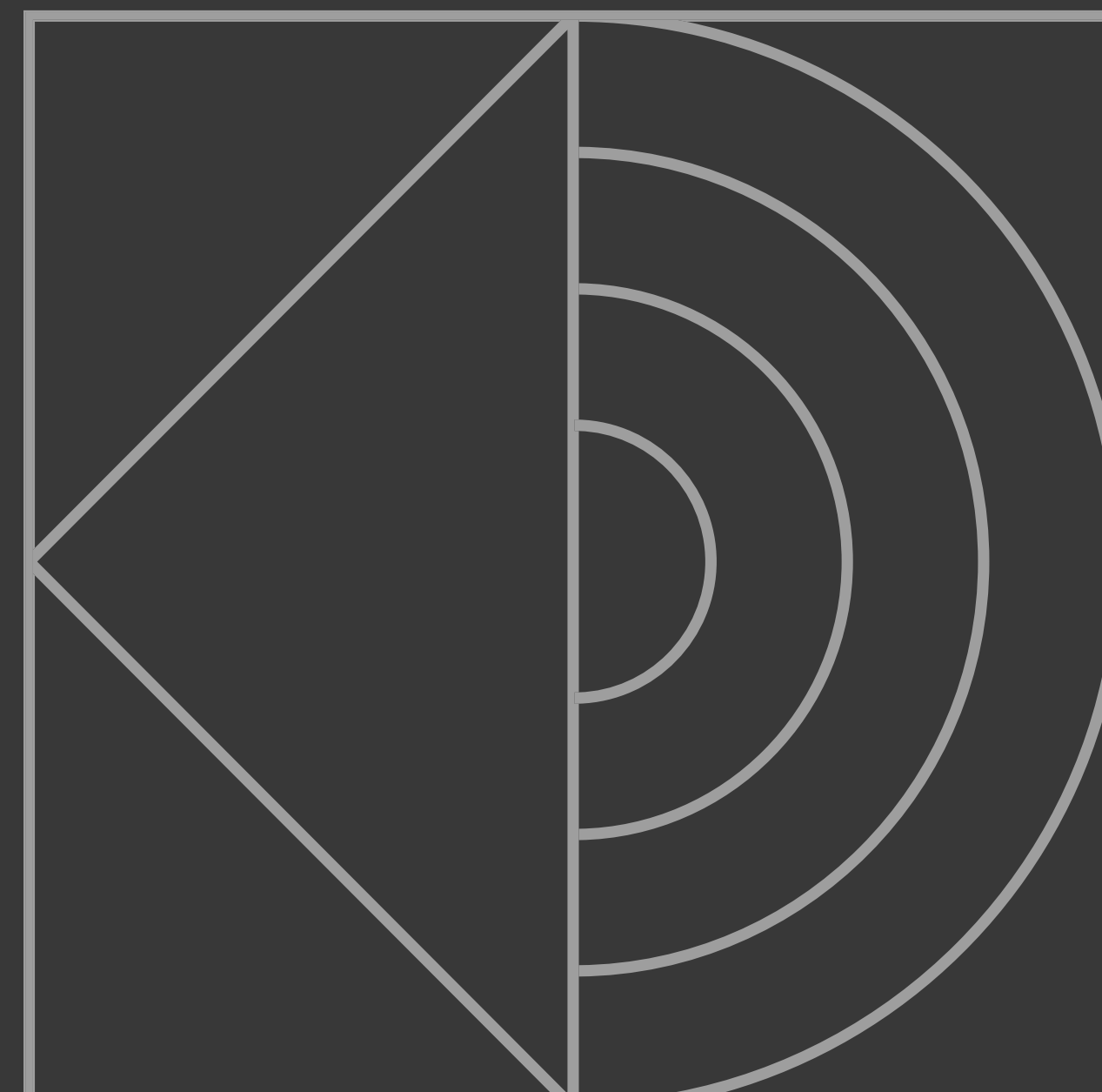

“I need brand assets that make an immediate impact during my limited engagement.”

We create powerful, implementation-ready brand systems that allow you to deliver measurable results within tight timelines.

“I’m juggling multiple clients across different sectors and need a specialist partner for tech and manufacturing.”

Our deep sector experience means we understand the technical nuances - you can rely on us to get it right, leaving you free to focus on your broader strategy.

“I need to demonstrate clear ROI to justify marketing spend to technically-minded leadership.”

We create brand assets that not only look professional, they’re designed to deliver specific commercial outcomes you can measure and report on.

“

“As a Marketing Director, what impresses me most about this team is their focus on commercial outcomes. Since working with them, we’ve seen a 30% reduction in our sales cycles and consistently higher conversion rates on RFQs.”

Marketing Director,
Precision Technologies Group

We Hear Marketing Consultants

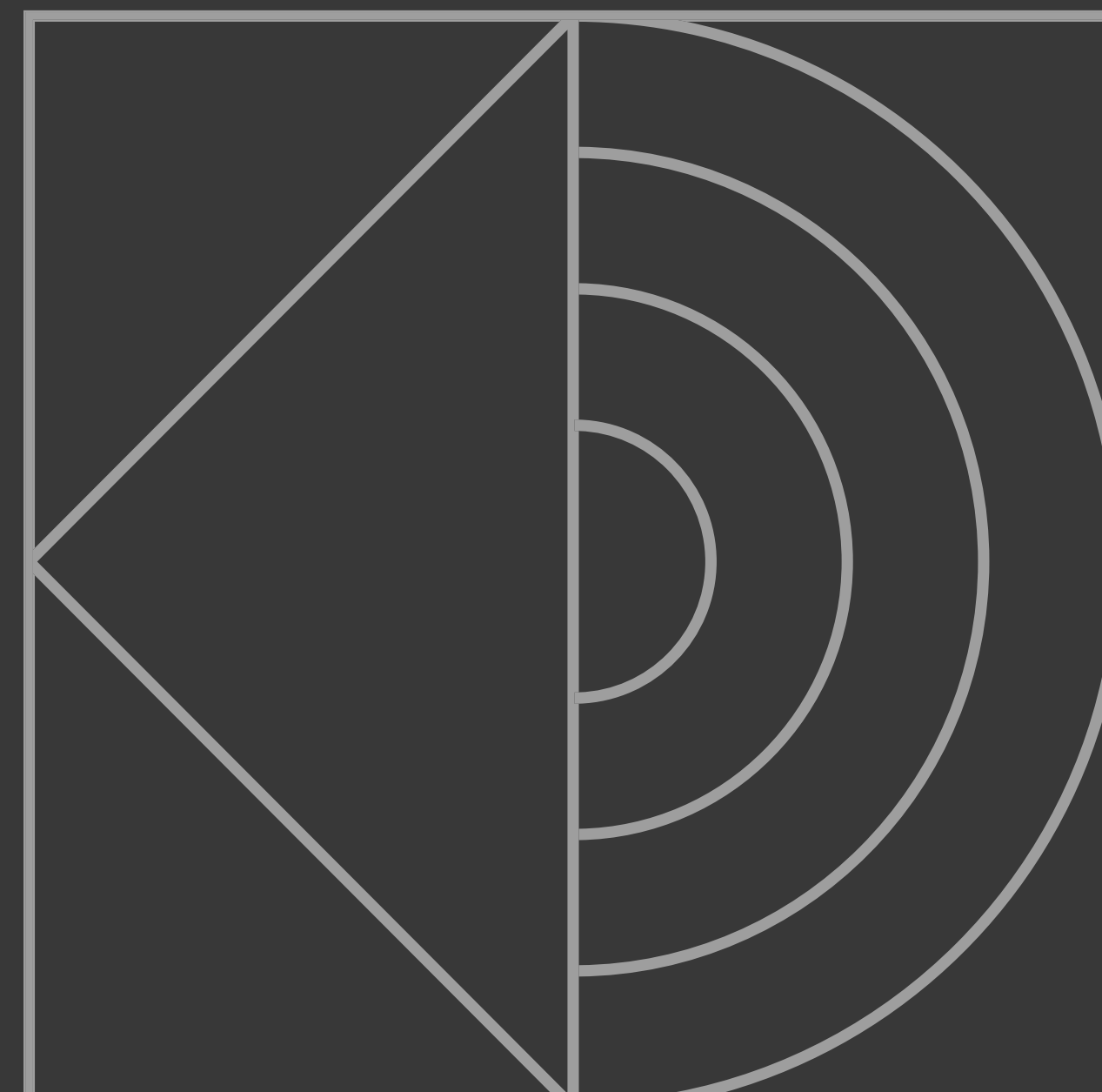

“I need a reliable creative partner who won’t let me down in front of my client.”

Our track record speaks for itself - we deliver quality work on time, so you look good and strengthen your client relationships.

“I need brand specialists who can translate technical complexity without requiring hand-holding.”

With 14 years in tech and manufacturing, we speak the language of your clients—no lengthy onboarding or explanation required.

“I need a partner who respects my client relationship while complementing my strategic input.”

We understand boundaries and operate as a partner, to help you grow your consultancy offering without ever overstepping.

“

*“Ad qui cullaut quid excestist, officil-
lores ratus, eatquasint.
Rio. Idis audi re essequo doluptas dit
autet eum fuga. Neque sam re cone
aligend ipsaperum, sequisi ommolup
tatibus, et liciisc iaeperum quis aris
suntum ex et voloribus a vellores si-
mus imil is inus asitisi dolorum”*

Marketing Consultant,
Precision Technologies Group

A Proven Formula

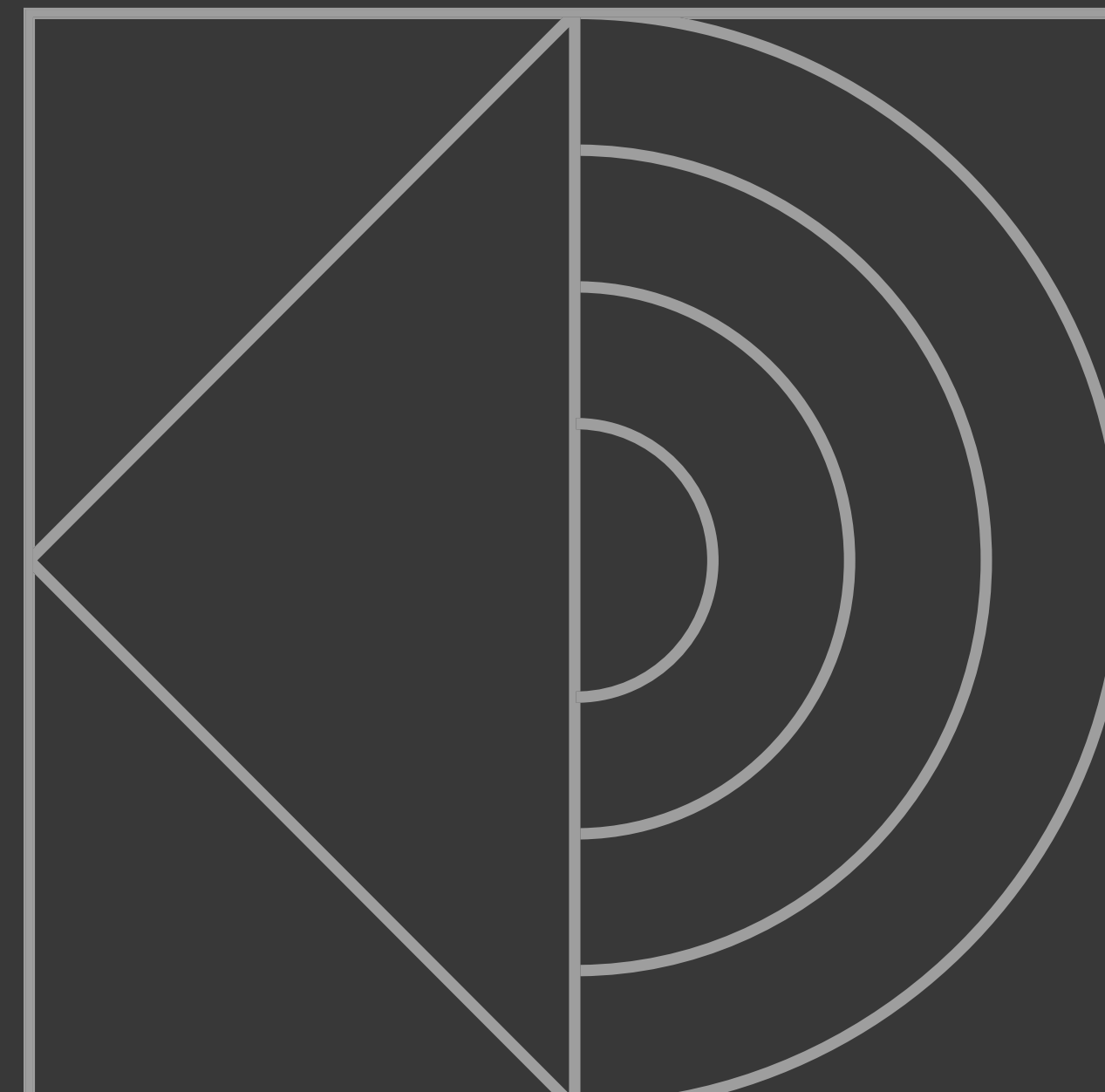

A Winning Formula

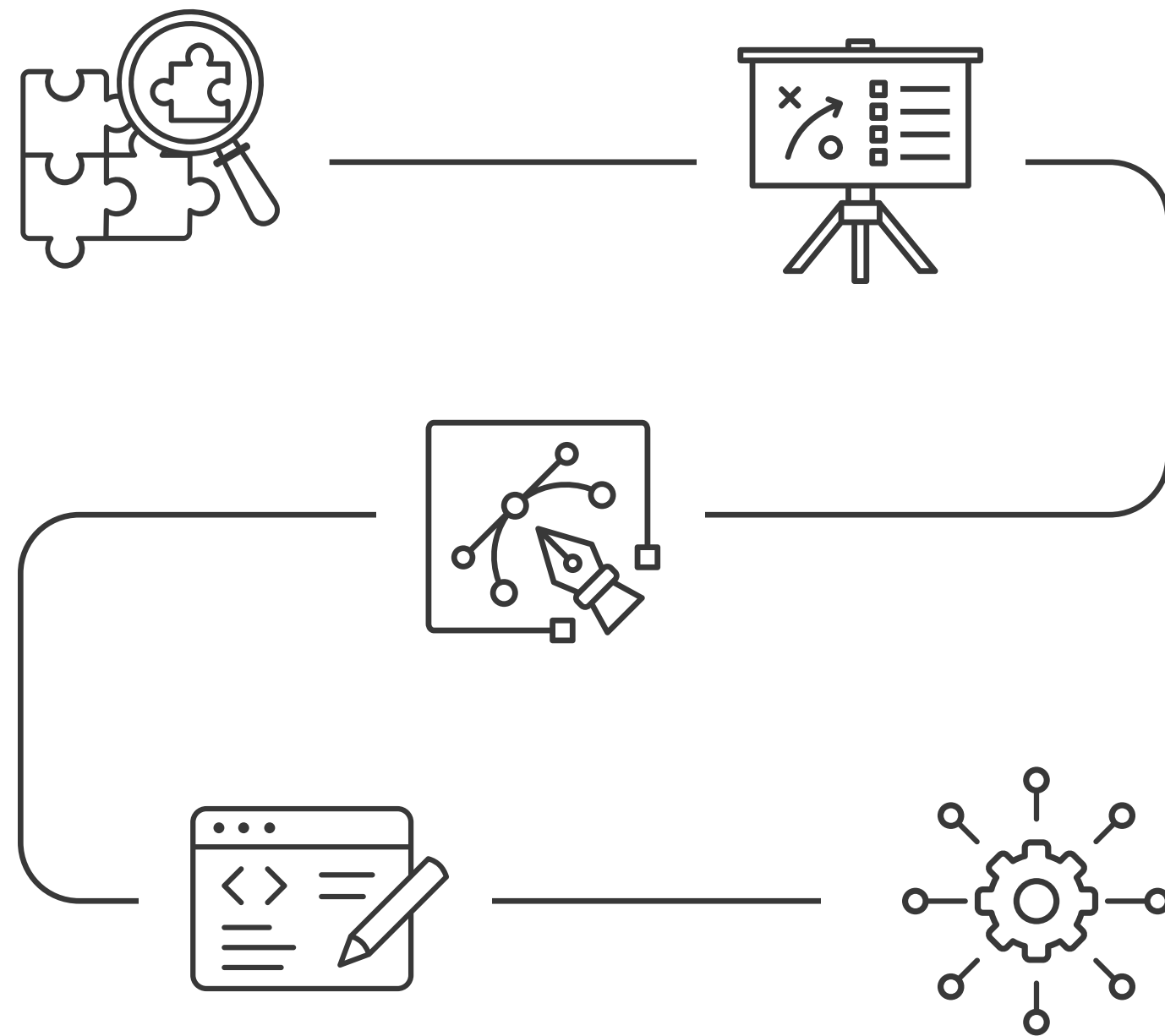

01. Discovery

Your capabilities, commercial objectives, and target audiences are unique. We listen, we learn - a collaborative approach, we become an extension of your team.

02. Development

We create a marketing strategy to meet your innovation timeline, from R&D announcements through to market launch and ongoing sales support, to make sure your campaign evolves alongside your technical development.

03. Craft

We develop distinctive visual and verbal identities that position your company as a leader in your field, creating recognition and building credibility with potential clients.

04. Delivery

From sales and investor decks to websites, exhibition materials and presentations, we make sure your brand image and messaging is consistently impactful across every touchpoint.

05. Ongoing Support

We keep an eagle eye on campaign performance and commercial metrics to refine our approach based on market feedback and sales data.

Support That Works The Way You Work

We understand that different companies have different needs. That's why we offer multiple ways to work with us:

Project-based

Complete delivery of specific project briefs with clear deliverables and timelines.

Marketing Packs

Tailored packages combining essential marketing elements at value-driven pricing.

Team Partner

We act as your outsourced creative team, providing ongoing support throughout your product development journey.

Contact us for more information.

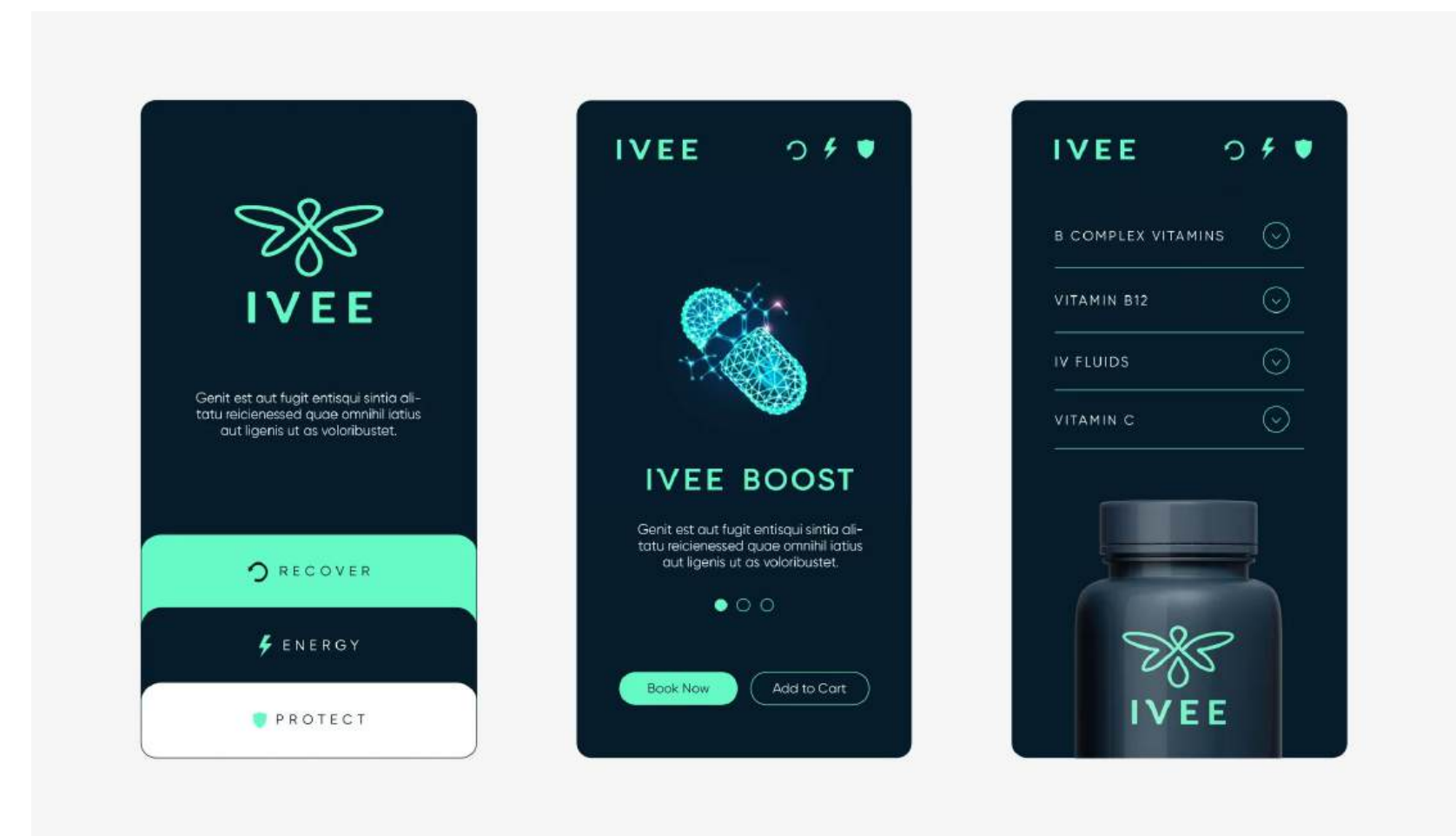

Why Choose Us?

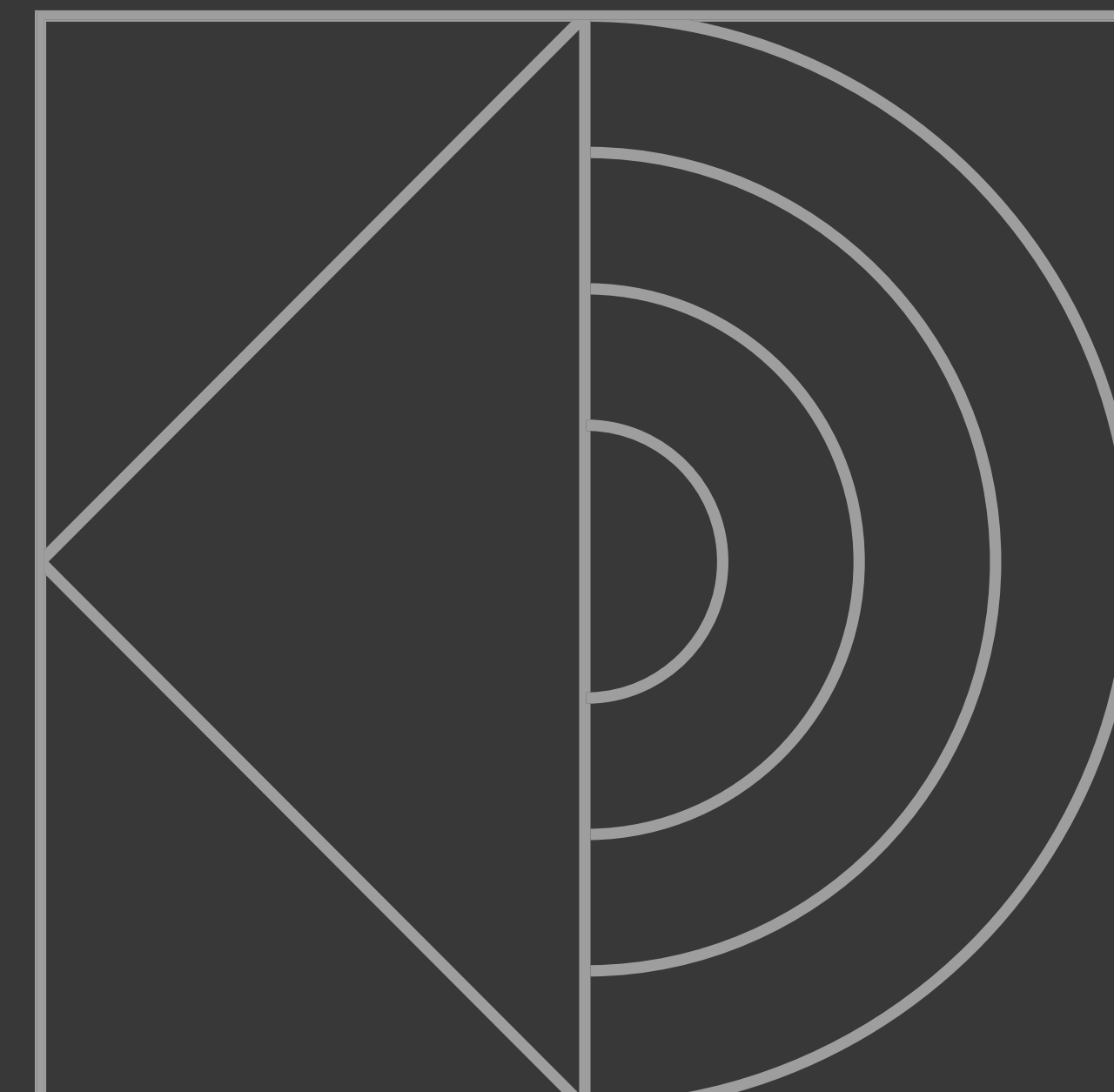

Sector Specialists

14+ years of deep industry experience across manufacturing, engineering, and technology sectors saves you time, money and endless explanation.

Technical Understanding

We're quick to grasp complex concepts and translate them into compelling communications. Compelling communications at the intersection of what you do best and what your clients need most.

Senior Support

We take personal responsibility for every stage of every project. No passing you around between different contacts.

A Focus on the Numbers

Always results focused, our work exists to hit your sales targets, shorten your sales cycles, and bring in quality leads efficiently – not just win creative awards.

Flexible

Product development rarely goes exactly to plan. We understand that. Professional and flexible, we're able to react quickly to changing timelines, specification updates, and feedback from the market without making a fuss.

Everything Under One Roof

We handle all your brand needs in one place, keeping everything consistent and efficient from day one.

Quality Work Without London Price Tags

Professional, top-notch creative work at sensible Northern rates. Why pay "that there London tax"?

Always Current

We continuously evolve our approach as markets, technologies, and communication channels change—ensuring your brand remains relevant and effective without chasing short-lived trends

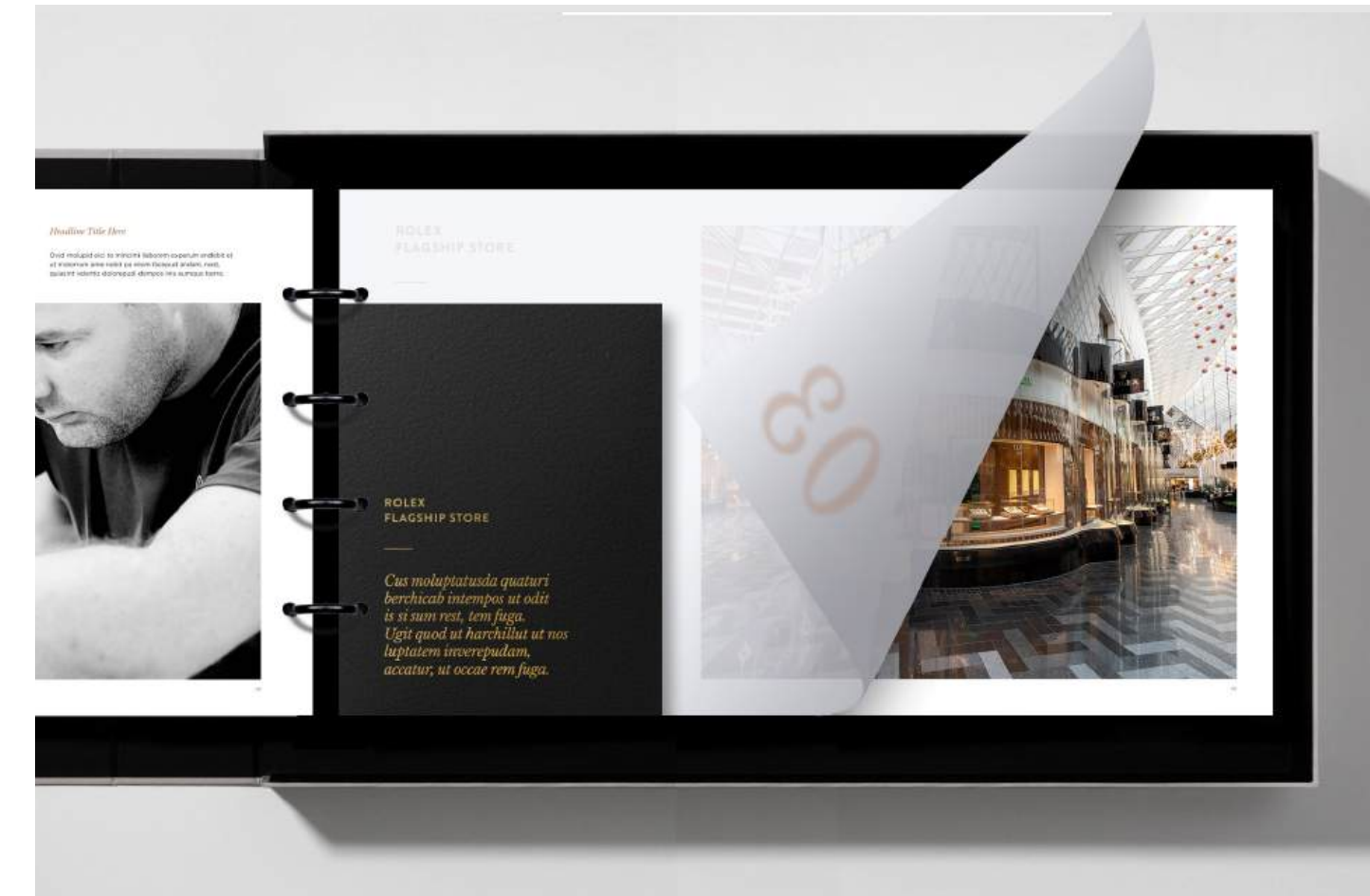

Services

Brand Identity

Logo & visual identity
Typography & colour palette
Iconography & technical illustrations
Brand guidelines

Strategy

Market positioning
Campaign planning
Brand Tone of Voice
Innovation communication
Budget optimisation

Digital Development

Website design & development
Interactive product demonstrations
Technical specification sheets
Email marketing
Social media campaigns

Brand Assets & Collateral

Technical brochures & sales packs
Exhibition stand design
Presentation templates
Product catalogues
Direct mail
Technical illustrations
Product photography
Process animations
Demonstration videos
Technical diagrams

Messaging & Copy

Product/service naming
Brand Tone of Voice
Copywriting
Value proposition development
Sales materials copy
Website content
Case studies

What Our Clients Say

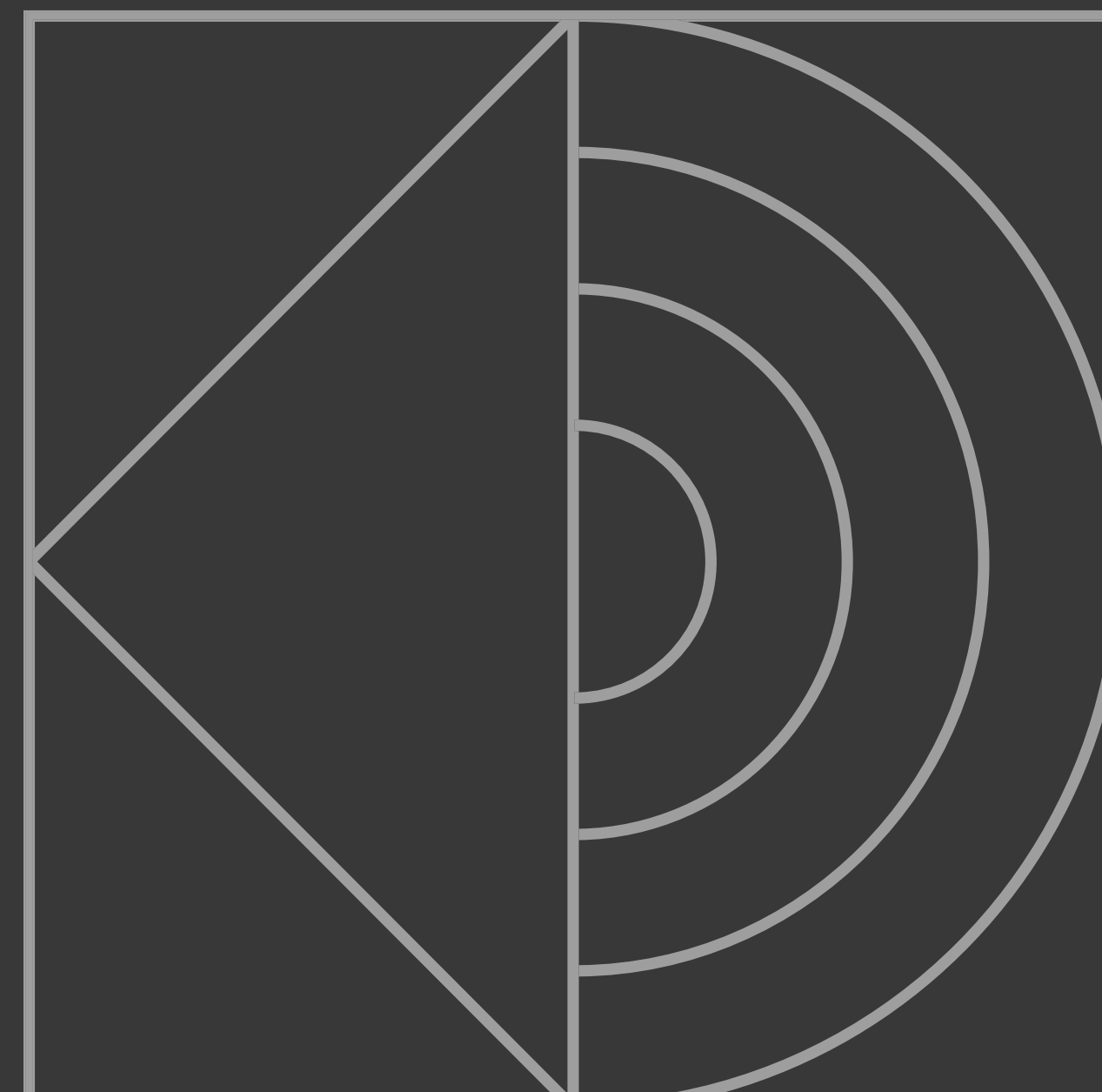

“

“I recommend this agency to anyone who wants engaging, impactful content and words that really do win business.”

Marketing Director,
handl Group

“

“Their ability to translate complex technical concepts gives us an edge when competing for contracts. They make our innovations understandable without oversimplifying them.”

CTO,
Industrial Automation Systems

“

“Their technical understanding has been invaluable in positioning our engineering capabilities authentically to non-technical decision-makers.”

Technical Director,
Precision Components Ltd

“

“Such a great process. It totally made us take a step back, think about how we communicate and how we want to communicate. It’s great to have defined a new shared voice.”

Operations Director,
Manufacturing Innovations

Our Work

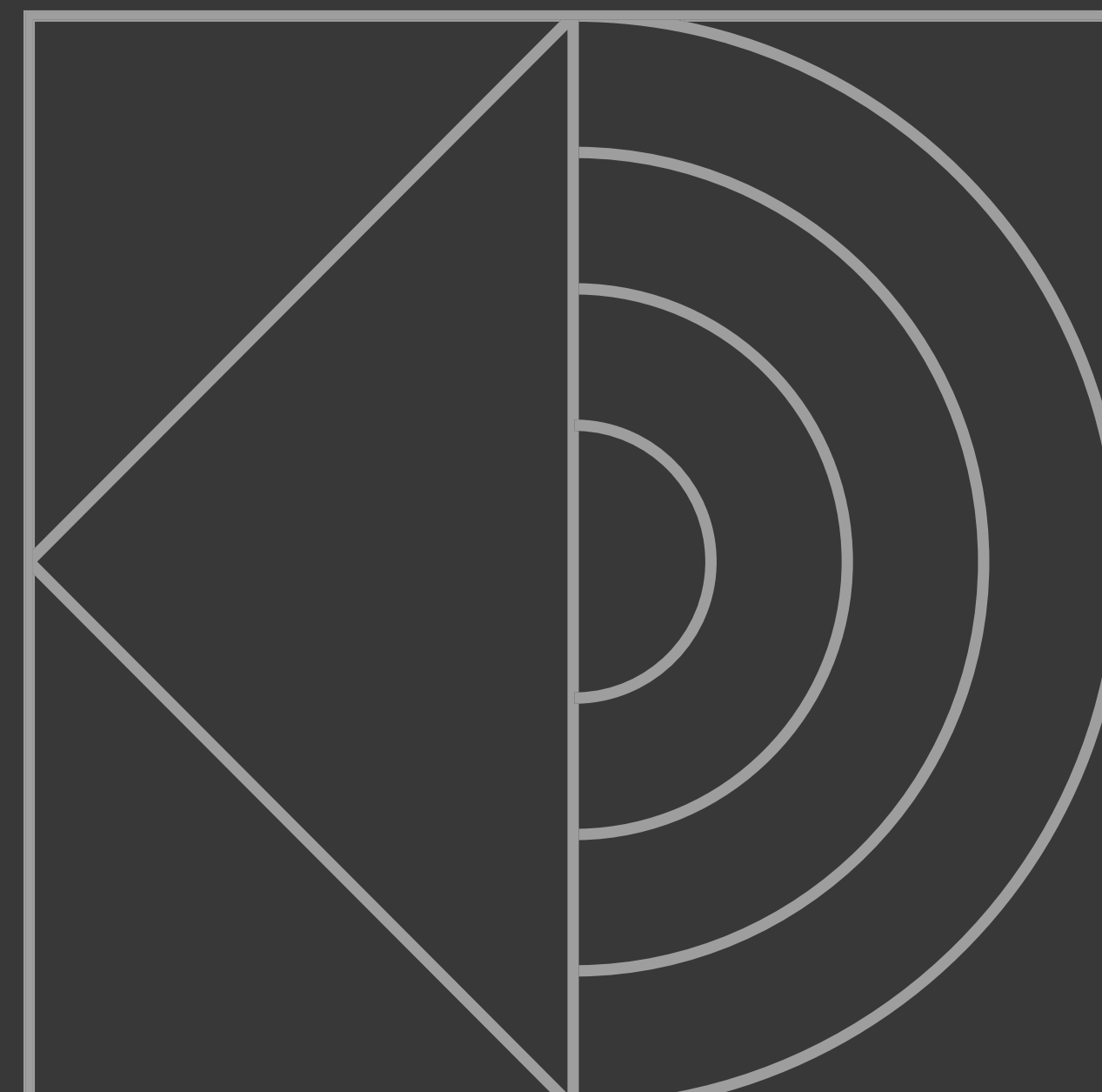

HHydrOdrive

HHydrOdrive is a Hydrogen Oxygen (HHO) fuel efficiency device that instantly cuts fuel consumption and emissions by 20%. We created a brand identity that uses road markings to carve out the letters HHO whilst also building a full brand suite to ensure this new product is ready to launch in the UK market.

- Naming Strategy
- Brand Identity
- Brand Guidelines
- Custom 3D Animation Render
- Sales & Pitch Deck
- Brochure Design
- Brand Messaging
- Website Copy
- Email Campaign Copy

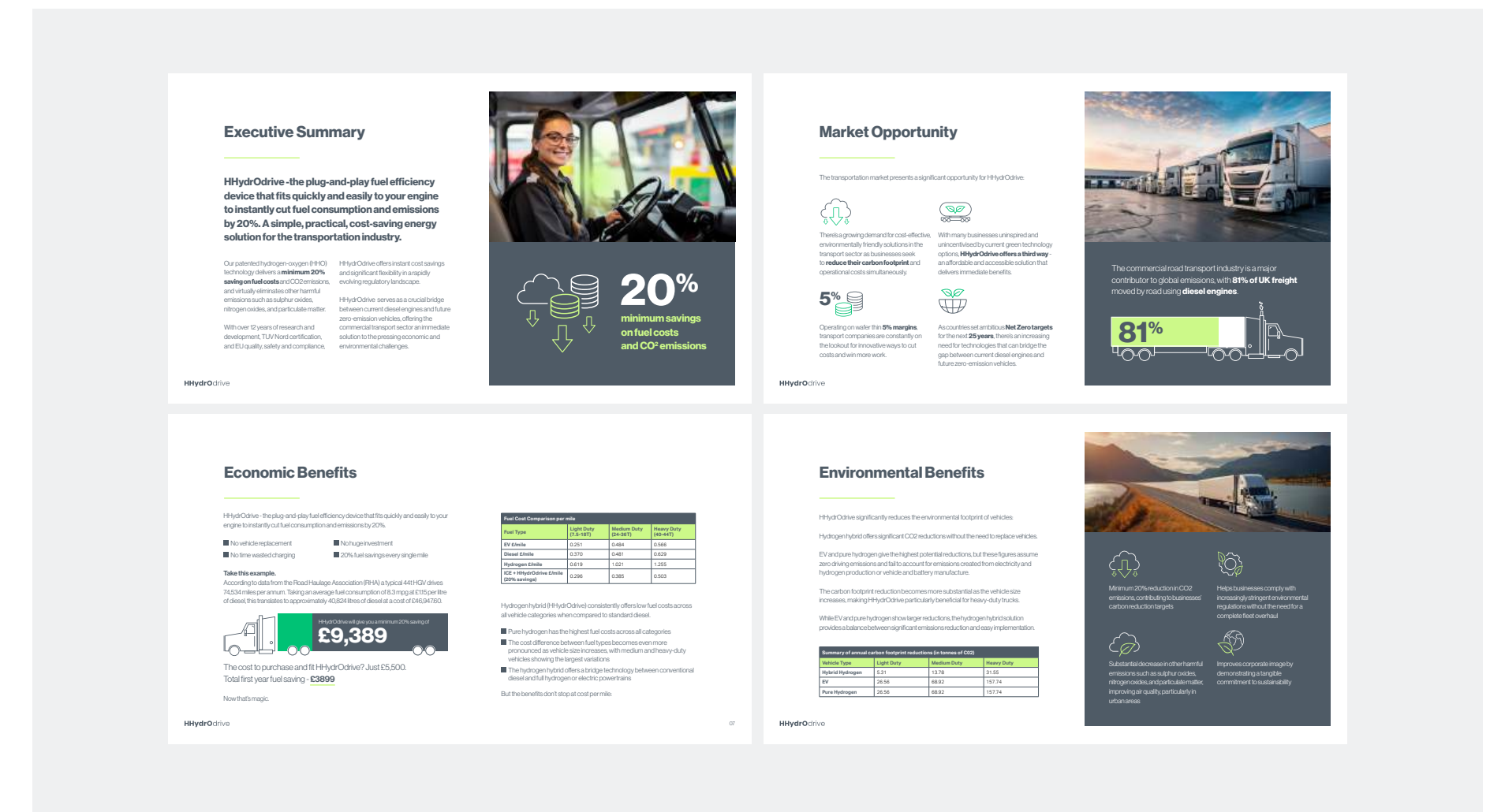
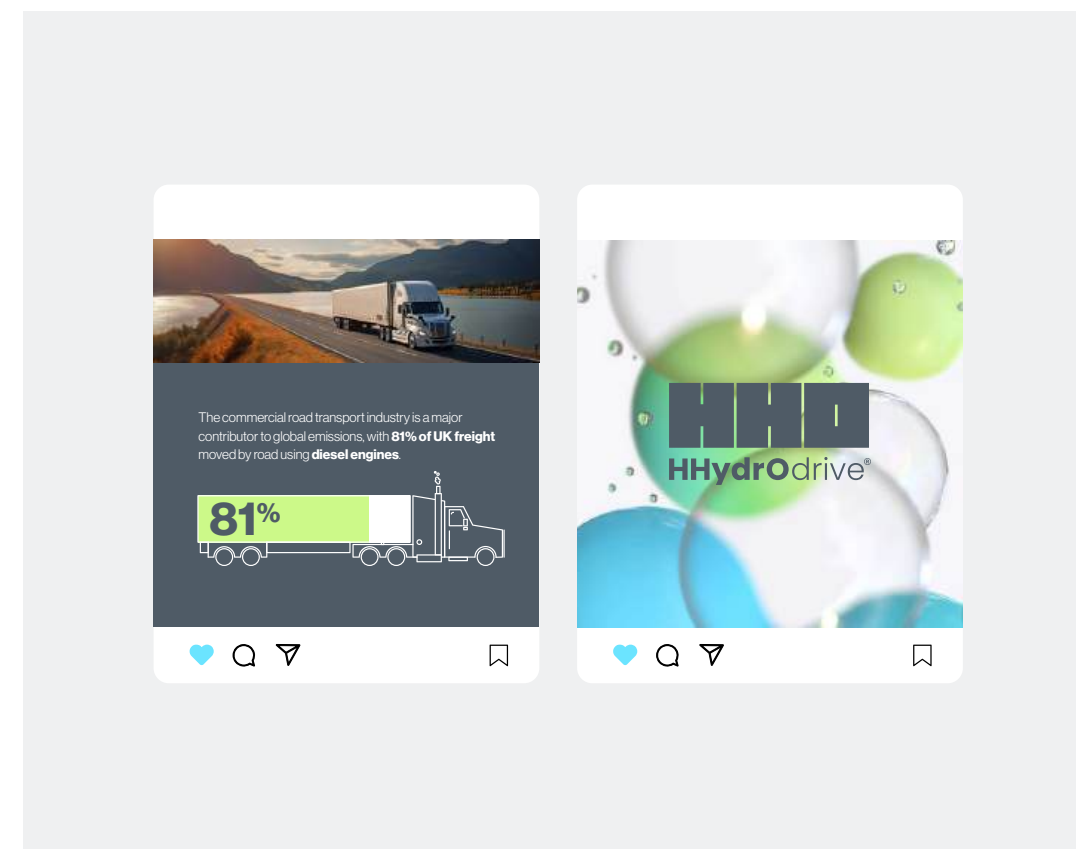
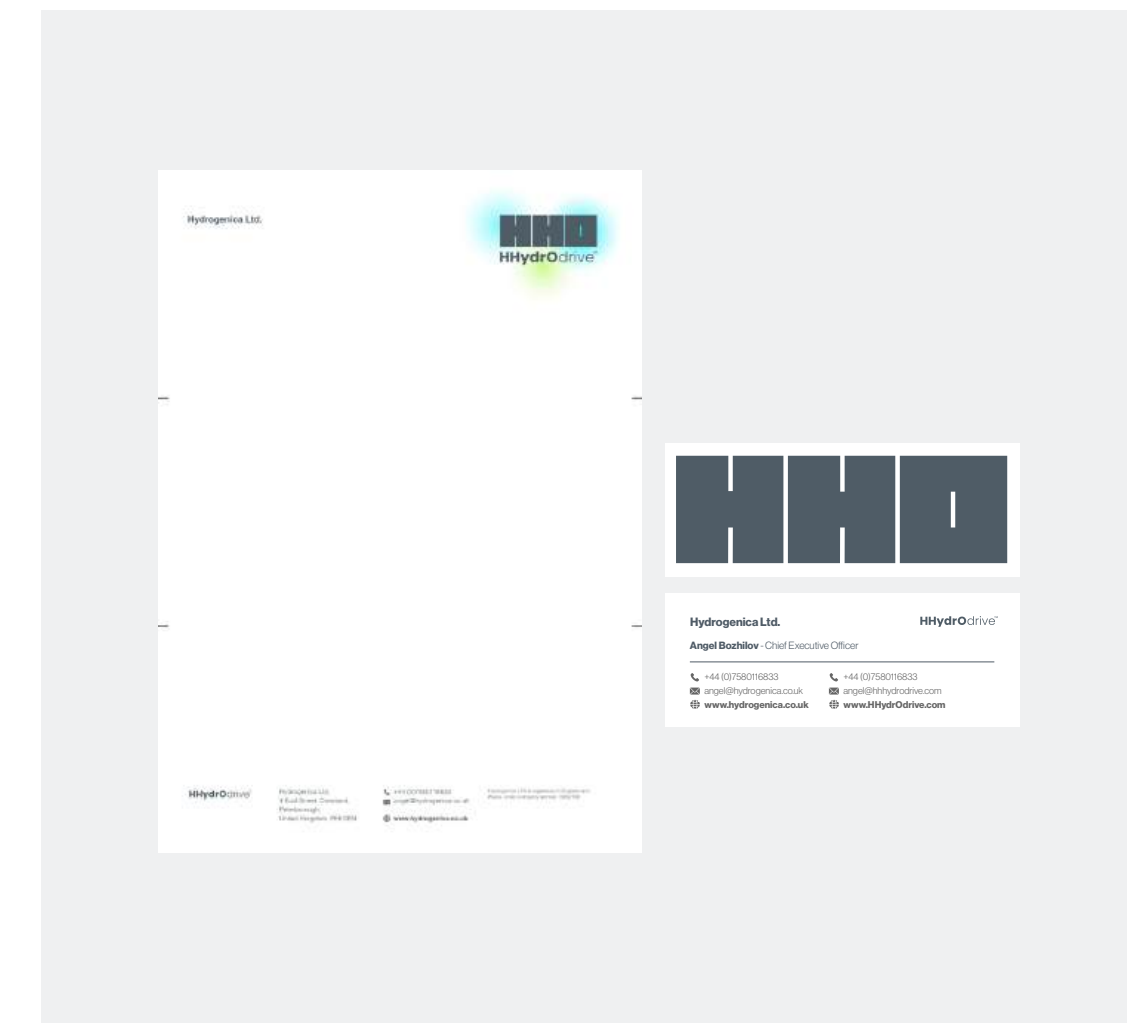

MSS International

For more than 50 years MSS International has delivered precision- engineered components and bespoke assemblies to the energy sector. They're the best in the business. Our rebrand reinforces their reputation as a global leader and helps project their ambitious vision for the future.

Brand Identity

Brochure Design

Catalogue Design

Exhibition Stand Design

Group Brand Architecture

Powerpoint Presentation Deck

Brand Guidelines

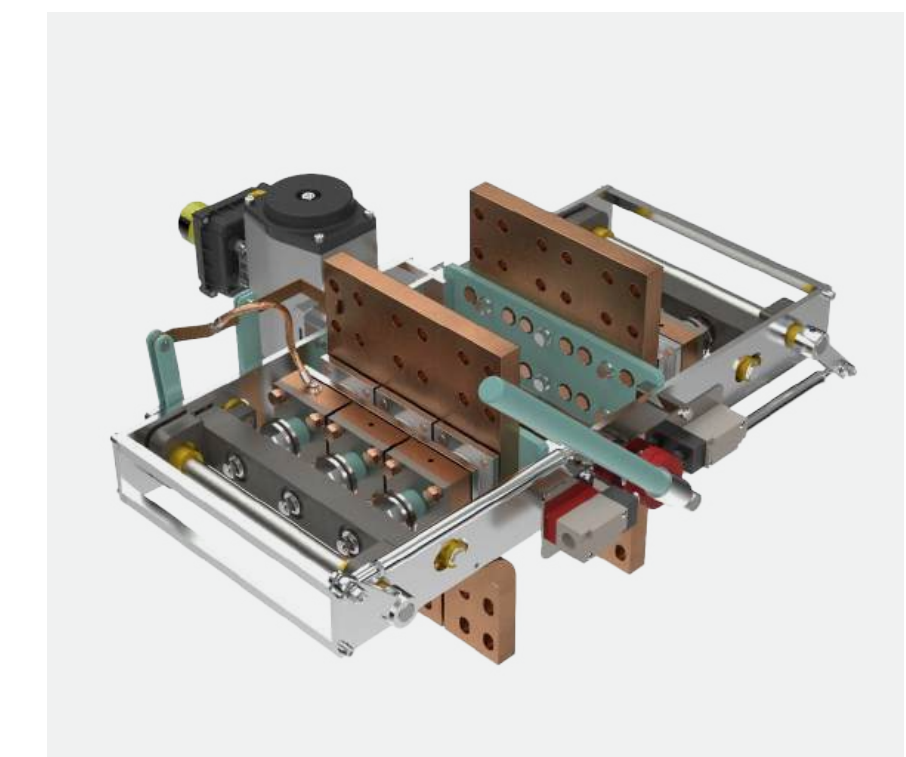

Tela

The all-in-one SaaS solution built by drinks distributors for drinks distributors. As a completely new product our strategy workshops led to a full brand and verbal identity package for a clear, seamless and concise entry to market allowing the team to hit the ground running.

Naming Strategy

Brand Identity

Brand Messaging & Tone of Voice

Brand Guidelines

Sales & Pitch Deck

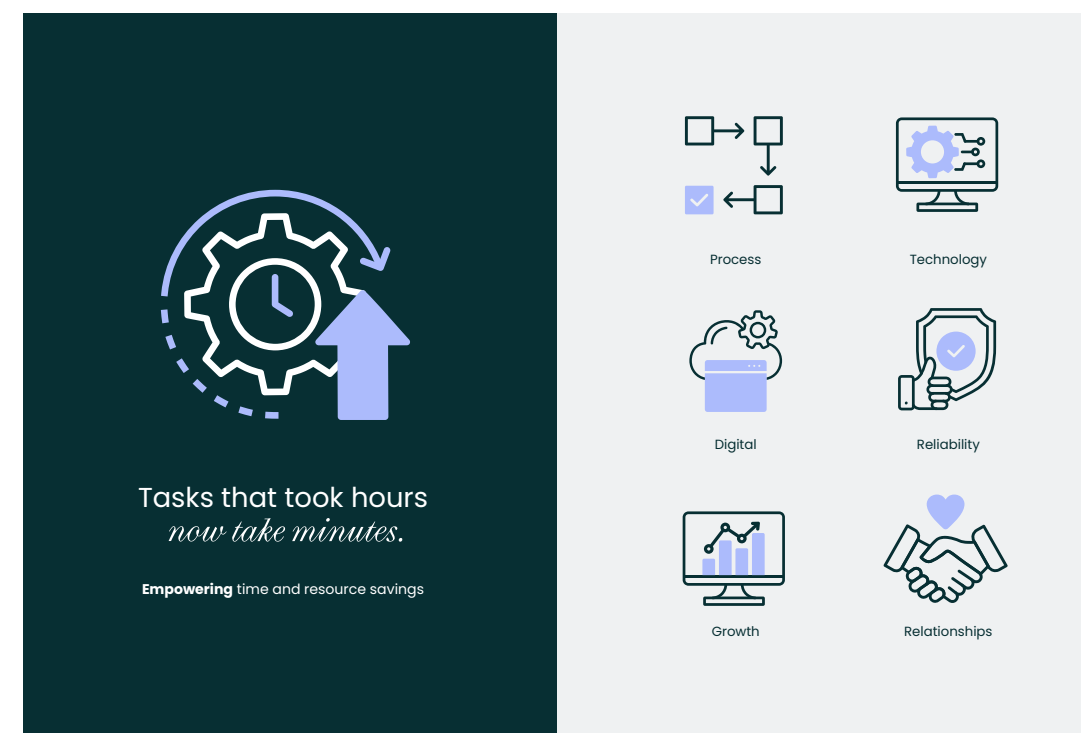
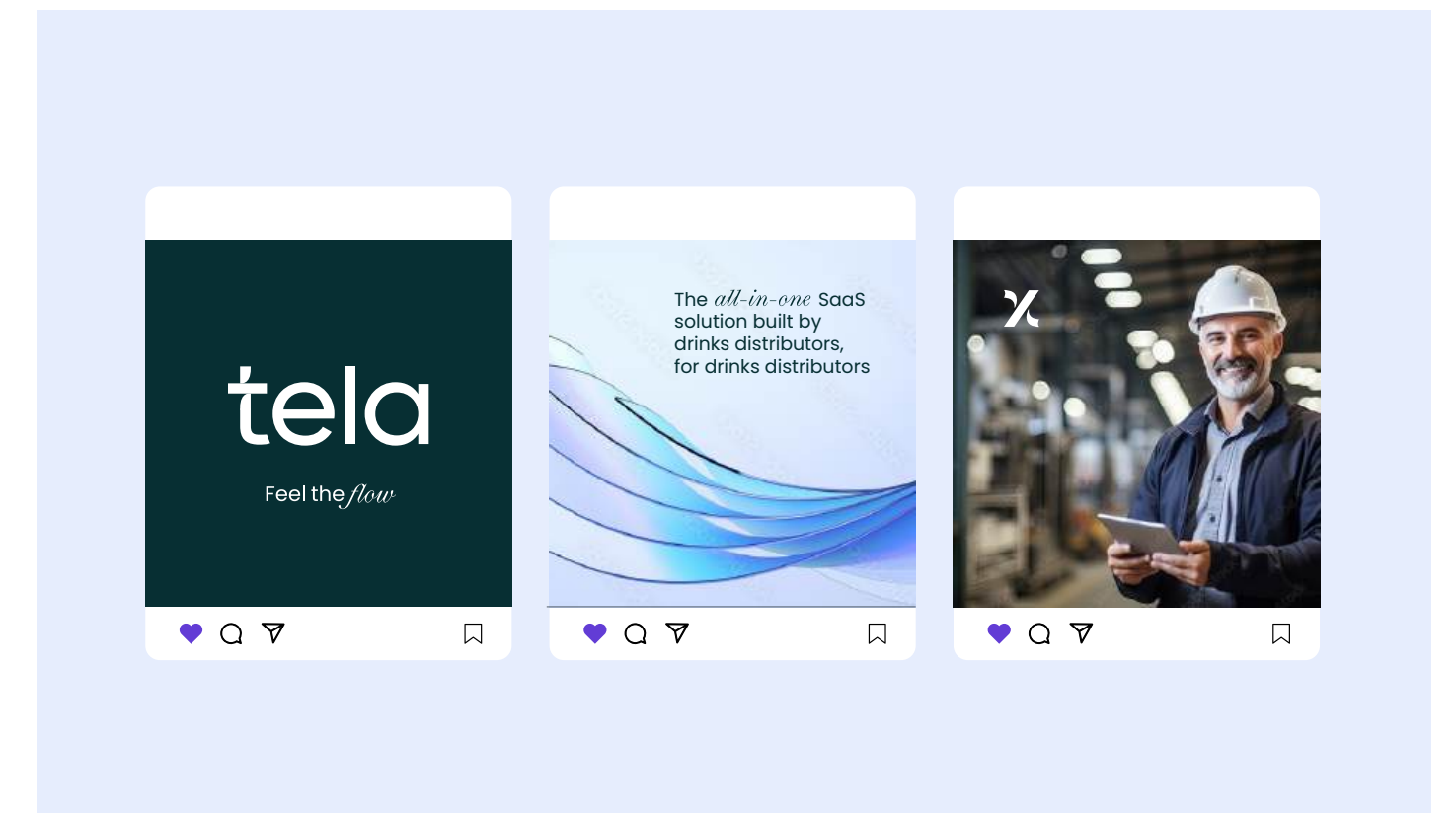

Let's Talk

Ready to discuss how we can support your next brand or marketing challenge?

Contact us for a consultation, where we'll discuss your specific challenges and how our approach could work for you.

info@hnwagency.com

